

Product Description

LUX ELEMENTS®-TUB-PUMP are hard foam shower base elements with integrated and sealed floor drain pump and an incorporated slope including 2 substrate elements. The shower base elements consist of a hard foam core made from expanded polystyrene with a double-sided glass fibre fabric reinforced special mortar coating and top-surface, factory finished sealant.

System components

- **LUX ELEMENTS®-DRY-DB** is a sealing tape fleece backed on both sides, which is ideally suited for wall/floor connections and for the formation of wall corners.

 - width: 100 mm
 - thickness: approx. 0,6 mm
- **LUX ELEMENTS®-DRY-DBIE/AE** are deep drawn interior or exterior corners fleece backed on both sides, which are ideally suited for fast and secure formation of corner seals (suitable for LUX ELEMENTS®-DRY-DB).
- **LUX ELEMENTS®-DRY-SB** is a self-adhesive fabric tape which was specially developed for the protection of sealing tapes when renewing permanently elastic service joints (silicone joints).
- **LUX ELEMENTS®-DRY-ASK** is a single-component, water-impermeable, crack-bridging and flexible sealing compound.
- **LUX ELEMENTS®-COL-FLEX** is a flexible cement powder adhesive suitable for the thin-bed adhesion in accordance with DIN 18157 Part 1 of:

 - of ceramic tiles, panels and mosaic
 - fine stoneware
 - discolouration-resistant natural stone panels
 - ceramic coatings in pools

LUX ELEMENTS®-COL-FLEX meets the C2TE-S1 requirements according to EN 12004 and EN 12002.

Applications

LUX ELEMENTS®-TUB-PUMP shower base elements must be finished off with ceramic covering. The floor drain pump can be used wherever wastewater cannot reach the drainpipe by gravity flow. This can be the case, for example, in old buildings, in the attic or in the cellar. The shower base elements can be utilised for all applications where the applicable building and safety regulations prescribe the requirement for barrier free construction methods such as e.g. homes for the elderly, disabled person's dwellings, etc. but, of course, also when comfort and optical appearance are deciding factors for modern constructions. Thus our shower bases $\geq 120 \times 120$ cm and $\leq 150 \times 150$ cm are certified according to the appropriate standards.



The LUX ELEMENTS®-TUB-PUMP products are equivalent to the bonded panel-type sealing materials described in DIN 18534 Part 6. They are usable for the water action class W2-I as AIV-P. We would ask that you consult our Technical Department before using them in the water action class W3-I.

The LUX ELEMENTS®-TUB-PUMP shower base elements comply with the requirements for constructional waterproofing when utilised in conjunction with ceramic tiles and pavings in accordance with Building Regulation Lists A Part 2, current No. 2.50. The range of application refers to moisture exposure class A for directly exposed floor areas in rooms in which service or cleaning water is frequently or continuously used, such as e.g. transitional areas in swimming pools and shower units (public and private).

General Building Authority Approved Test Certificate No. P-AB/20802/05-2008 issued by Kiwa MPA Bauteist GmbH Niederlassung tBU Greven.

Furthermore, the LUX ELEMENTS®-TUB-PUMP shower base elements are system components for the LUX ELEMENTS®-WATERTIGHT SOLUTION sealing system and fulfil the directive for the European Technical Approval for 'Watertight covering kits for wet room floors and or walls - Part 3: Kits based inherently on watertight boards', ETAG 022-3.

Substrate

– rigid, load-bearing, clean and vibration-free mineral or wooden floors

Recommended use

LUX ELEMENTS recommends the LUX ELEMENTS®-TUB-TSM for sound-decoupled installation. Acoustically isolate the pressure pipe, connect it to the pressure outlet with a 1" female thread and route it to the nearest downpipe. To reduce the transmission of sounds to a minimum, care should be taken when installing that the pump housing is installed without sound bridges.

The LUX ELEMENTS®-TUB-PUMP shower base elements can be shortened. In all cases, a 50 mm wide margin must remain, measured from the edge of the floor drain pump. We must hereby draw attention to the fact that LUX ELEMENTS®-TUB-PUMP shower base elements, which are not circumferentially shortened with the same dimensions, will have different external thicknesses due to the built-in drain-off slope and will therefore have an offset to the adjacent floor.

Holes (Ø 5 mm) can be drilled all round in the edge above the factory seal for the secondary drainage.

Please pay attention to the 'LUX ELEMENTS®-TUB-PUMP Instructions for assembly'

Covering materials

The LUX ELEMENTS®-TUB-PUMP shower base elements have been specially designed for cladding with ceramic covering materials. The ceramic covering undertakes the function of the load distribution layer. The loads that can be anticipated in use are to be specified by the specialist planner. The covering must be selected according to the specified load.

Irrespective of minimum loads or higher resistance requirements (e.g. wheelchairs of up to 200 kg), the front elevation can be cladded with adhered mosaic $\geq 20 \times 20 \times 4$ mm in conjunction with adhesive and grouting with reactive resin. If the size of the tiles is $\geq 50 \times 50$ mm, tile adhesive of quality grade C2 can be used for gluing and a cementitious grout material for joining. Please pay attention to our General Building Authority Approved Test Certificate No. P-AB/20802/05-2008 from tBU GmbH and/or our European Technical Approval according to ETAG 022-3 when covering our shower base elements with covering materials. The breaking strength of the tiles and/or mosaics must be considered accordingly. The shower base element should not be subjected to loads greater than 0,1 N/mm².

LUX ELEMENTS®-TUB-PUMP shower base elements must be protected against damage to the sealing between the installation and the subsequent tiling. Even if subjected to incorrect use, e.g. stepladders for repair work, make sure load is evenly distributed.

The hydraulics of the floor drain pump can be removed from the motor, without the need for tools, for any maintenance/repair works.

Technical Specification

■ **Technical Specification of the shower base element**

- Overall height of shower base element 45 mm [*]
- Integrated slope from 45 mm to 30 mm [*]. The design of descending gradients and directions must be executed by the technical planner. Special designs up to a maximum thickness of 65 mm are possible apart from the descending gradients stated here.
- Pressure strength of 0,1 N/mm²
- * Standard (other values possible)

■ **Technical Specification of the floor drain pump**

- Pump: Horizontal, one-stage pump with efficient, maintenance-free synchronised motor with blocking-free hydraulics. Winding thermostat for protecting the drive unit against overheating, automatic switching via the float switch. Pressure connector (1") with integrated non-return valve. VDE-Approval.
- Material: Base draining pump made from high-resistant synthetic material. Grate and attachable profile from stainless steel 1.4301, load class K3 (up to max. 300 kg)
- Seal: Internal seals made from NBR

Electrical data

- Power supply: AC
- Voltage [V]: 1/N/PE~230
- Motor performance: P1: 30 W (TUB-PUMP-S ...); 65 W (TUB-PUMP ...)
- Current: 0,20 A (TUB-PUMP-S ...); 0,44 A (TUB-PUMP ...)
- Motor protection: in the winding
- Plug: N/A
- Cable length: 5 m
- WEEE Registration number: DE31719333

Performances

Pumping height H [m]	0,1	0,75	1,0	1,5	2,0
Output volume Q [l/s] TUB-PUMP-S ...	0,43	0,38	0,27		
Output volume Q [l/s] TUB-PUMP ...		0,77	0,67	0,52	0,33

Characteristic curve

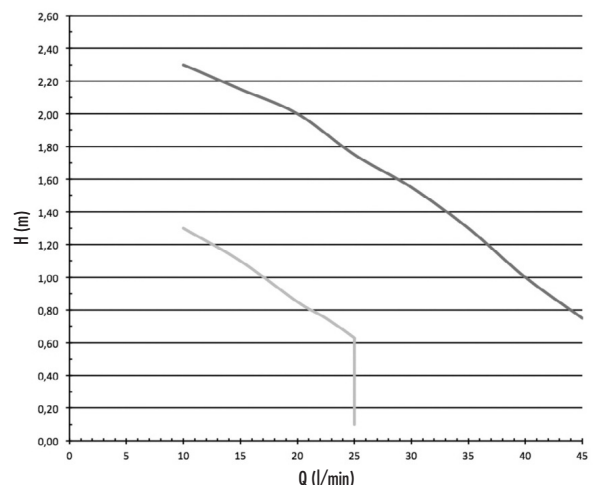

- The installation material for creating the pressure pipe is not included in the scope of delivery and must be provided on site
- Approved material for pressure drainage pipe is PVC (DIN 8062), PE-HD (DIN 8074) and PP (DIN 8077)

Notice! When the pressure pipe is connected to the pressure outlet, do not seal the connection with hemp but wind not more than 6 layers of Teflon tape around the outlet.

Manufacturer of the floor drain pump: JUNG PUMPEN GmbH, Industriestraße 4–6, D-33803 Steinhagen,
Phone +49 (0) 52 04 / 17-0, Fax +49 (0) 52 04 / 8 03 68, info@jung-pumpen.de, www.jung-pumpen.de

■ **Installation on concrete slabs**

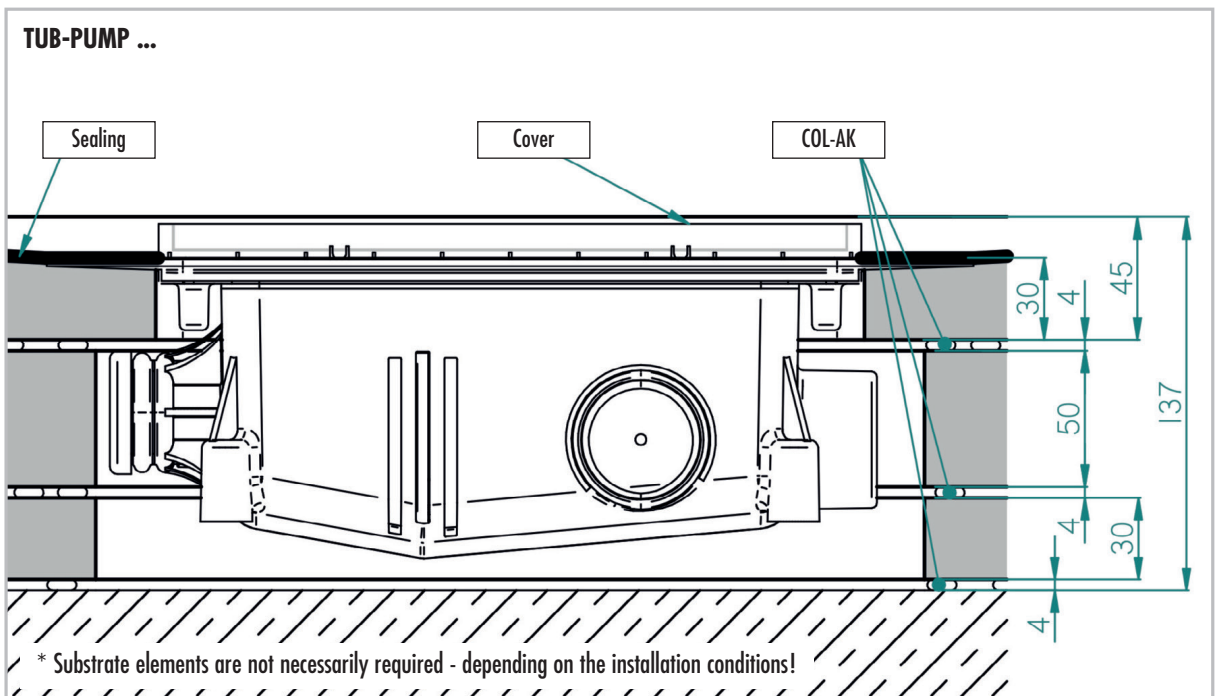
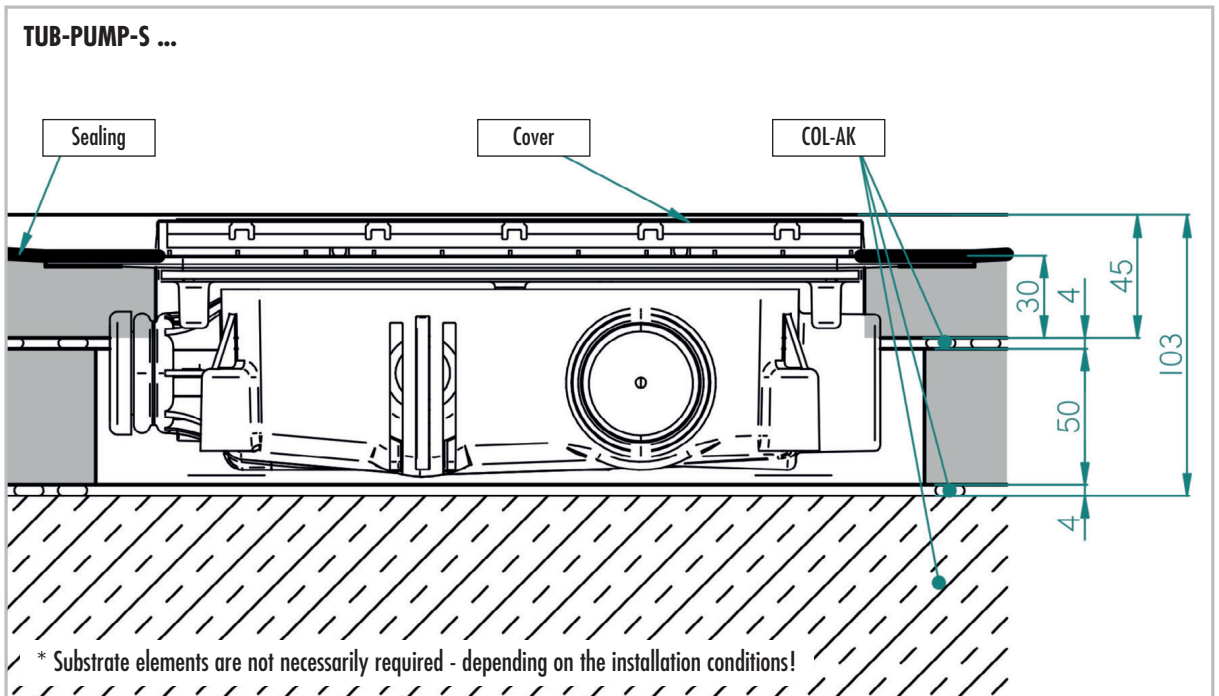

■ Installation on wood floors

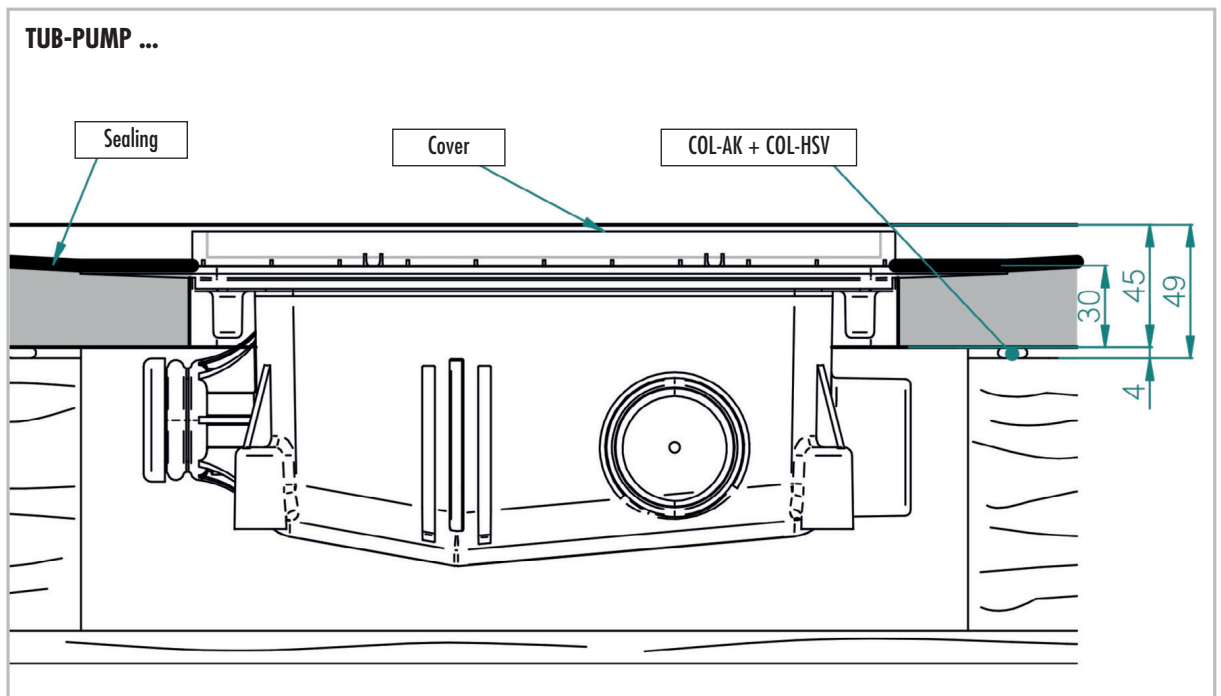
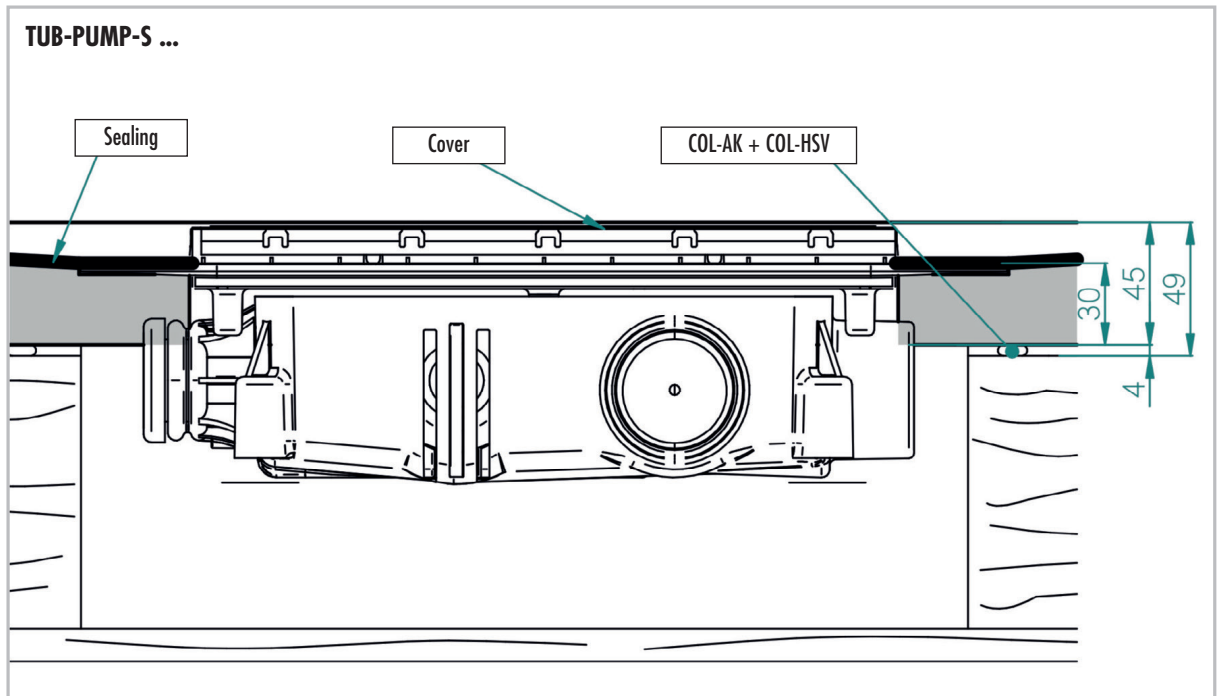

■ **Tile covering**

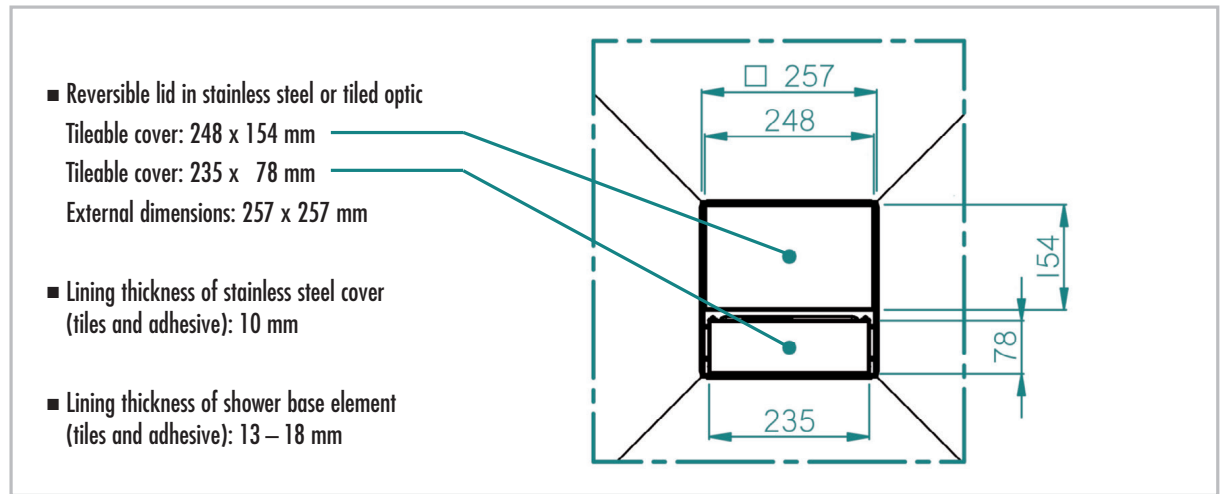

■ **In general**

Please note that with flush with the floor shower bases, in the case of

- a low slope
- rough ceramics
- the lack of a shower enclosure
- unfavourable shower head placement
- high water pressure or high quantity of water (e.g. in the case of flood showers)

water can run out of the shower area or accumulate. Please refer to our planning aids and FAQ's for the planning of shower bases on our website (www.luxelements.com).

■ **Accessories**

- Impact sound insulating mat:
LUX ELEMENTS®-TUB-TSM 6, 1250 x 1250 x 6 mm
LUX ELEMENTS®-TUB-TSM 12, 1250 x 1250 x 12 mm
 (see data sheet LUX ELEMENTS®-TUB-TSM)



The relevant recommendations and guidelines, as well as DIN regulations, European standards and safety datasheets are to be observed. The recognised architectural and technical rules apply. We accept liability for the perfect quality of our products. Our processing recommendations are based upon trials and practical experience; they can, however, be no more than general instructions without assurance as to their quality, since we have no influence on the site conditions, on the execution of the work and the processing. With the issuing of this product datasheet previous versions cease to be valid.

LUX ELEMENTS GmbH & Co. KG

An der Schusterinsel 7
 D - 51379 Leverkusen-Opladen
 Tel. +49 (0) 21 71/72 12-0
 Fax +49 (0) 21 71/72 12-40
info@luxelements.de

LUX ELEMENTS S.A.S

ZI-31, rue d'Ensisheim
 F - 68190 Ungersheim
 Tél. +33 (0) 3 89 83 69 79
 Fax +33 (0) 3 89 48 83 27
info@luxelements.fr